

Battery Charger User Manual

May 2008

Battery Charger User Manual 4 & 8 amps (2008 05 29).doc

Questions? Contact us!

www.helitowcart.com
info@helitowcart.com

tel: +1.418.561.4512
fax: +1.418.836.2291

860 Marie-Victorin, St-Nicolas, Levis, Quebec, Canada, G7A 3S9



Please give this manual to the owner of the Helitowcart.



Please read and familiarize yourself with this manual in it's entirety before using your battery charger for the first time. Read again this manual until you become familiar with it and pay close attention to the warnings.



Should you have any questions about subjects not covered in this manual, consult a technician from an authorized service dealer. Consult first page for manufacturers coordinates.



Do not install unauthorized accessories. Always consult a technician at an authorized service dealer for any modification to your battery charger.

Dealer: _____

Address: _____

Telephone: _____

Introduction

Vanair inc., maker of Helitowcart towing devices, is proud to count you among its customers and thanks you for having chosen one of its products.

All products manufactured by Vanair inc. respect or exceed the highest standards of quality and safety currently in force in the industry. The personnel at Vanair inc. is dedicated to customer satisfaction.

This battery charger user manual was conceived to enable you to safely use the battery charger supplied with your Helitowcart.

In order to optimize the performance of your Helitowcart and to prolong its lifespan, it is essential to have the battery charger checked regularly by a technician from an authorized service dealer.



CONTENTS

1.0 SAFETY REQUIREMENTS	5
1.1 Safety requirements	5
1.1.1 Safely using the battery charger.....	5
1.1.2 Cleaning and maintenance.....	5
1.2 About electromagnetic energy	6
1.2.1 Electromagnetic energy effects - caution	6
1.2.2 Using transmitters and receivers	6
2.0 RECOMMENDED USE	7
3.0 SPECIFICATIONS	8
3.1 Battery charger introduction	8
3.2 Functions and indicators.....	9
3.2.1 "On/off " Switch.	9
3.2.2 "On/off" Indicator.	9
3.2.3 Battery status indicator	9
3.2.4 Voltage selector.	9
4.0 UNPACKING	10
4.1 Battery types	10
4.2 Initial battery charger connection	11
5.0 OPERATING INSTRUCTIONS	12
5.1 Activating charger.....	12
5.2 Deactivating charger	12
6.0 BREAK DOWN SERVICE GUIDE	13
6.1 Charger lights do not ignite	13
6.2 Green light flickers.....	14
7.0 WARRANTY	15



1.0 SAFETY REQUIREMENTS

1.1 SAFETY REQUIREMENTS

1.1.1 SAFELY USING THE BATTERY CHARGER

IMPORTANT	Set voltage selector to appropriate setting PRIOR TO initial use. Select 115 or 230 Volts according to local electrical services. Failure to do so could lead to major battery charger damage.
------------------	---

SAFE USE (IMPORTANT):

- Set voltage selector to appropriate setting for initial use 115/230 Volts. Failure to do so could lead to major battery charger damage.
- Always make sure that connector linking to tow cart is fully inserted into tow cart socket to recharge batteries
- If your battery charger has an ON/OFF switch: Always set the ON/OFF switch in the OFF position prior to disconnecting cable from tow cart.
- Always unplug tow cart from battery charger prior to attempting any tow cart movement, failure to do so can result in battery charger and/or tow cart getting damaged

WORK ENVIRONMENT:

- Do not use your battery charger in a hermetic or non ventilated environment
- Do not immerse your battery charger. It could cause dangerous defects
- Do not store your battery charger under rain, wet or very cold place

MODIFICATIONS TO BATTERY CHARGER:

- Never attempt modification to battery charger electric circuit or connector
- Never connect to electric components other than those manufactured by Helitowcart (Vanair inc.).
- Always immediately replace any damaged electric cable
- Always perform maintenance to battery charger as recommended by Helitowcart.

1.1.2 CLEANING AND MAINTENANCE

- Clean battery charger using a soft rag and diluted soft soap
- Do not use alcohol or thinner based detergents
- Regularly carry out maintenance as recommended by Helitowcart

1.2 ABOUT ELECTROMAGNETIC ENERGY

- All electronic instruments which transmit remote information are generally apparatuses which emit some radio waves in the environment. These radio waves are called "electromagnetic energy".
- The proper operation of an electronic instrument can be deteriorated by this electromagnetic energy field. It is what we call "an electromagnetic interference". The stronger the intensity of energy, greater the risk of faulty operation of the apparatus. This energy is measured in volt per meter (V/m).
- All motorized Helitowcarts are subject to be affected by these interferences. However, current technology makes it possible to immunize them against these risks. It is what is called their electromagnetic level of immunity to the interference, measured also in volt per meter (V/m).
- The controller has been tested for compliance with EC directive 89/336/EEC, and the EMC requirements of PREN12184. The guidelines in this section will help you to make sure that your vehicle installation will easily meet the requirements of the directive.

1.2.1 ELECTROMAGNETIC ENERGY EFFECTS-CAUTION

- Waves emitted by the following devices can affect the correct operation of the battery charger:
 - Radio and television stations,
 - Amateur radio,
 - Radio transmitters and receivers,
 - Cellular phones.

1.2.2 USING TRANSMITTERS AND RECEIVERS

- Avoid proximity to sources of electromagnetic emissions.



2.0 RECOMMENDED USE

- The battery charger was designed to provide fast and secure charge to batteries for your Helitowcart . This battery charger is designed to perform initial charging & recharging of lead-acid batteries.
- Recommended battery charger for each tow cart model:

Battery Charger type	Tow Cart Model
4 Amps	V102,V204,V403,V404
8 Amps	V500,V524

Note: All pictures within this manual show the typical 4Amps battery charger model. The 8 Amps battery charger offers the same features except an on/off switch and an input fuse. It is also configured slightly differently from the 4Amps model. However, all the essential features are present and readily recognizable.

3.1 BATTERY CHARGER INTRODUCTION

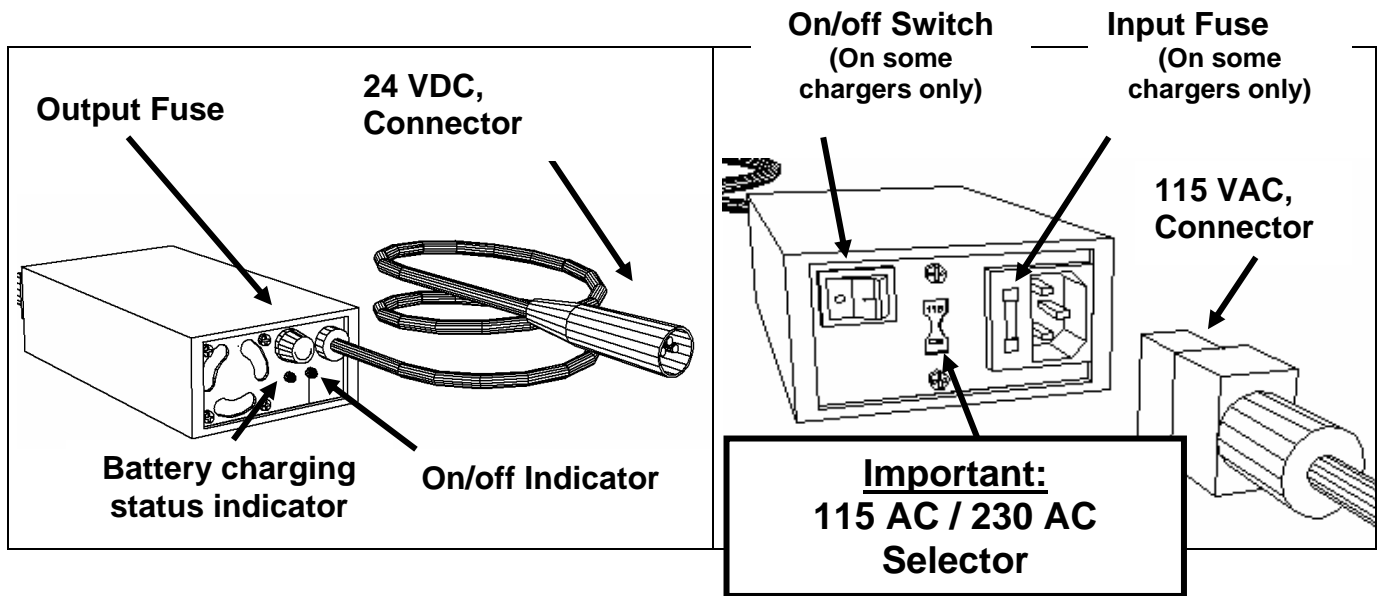
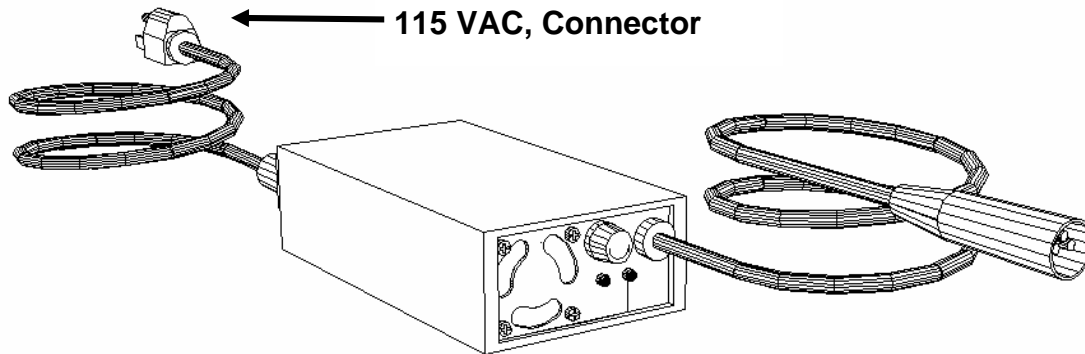

- The Helitowcart battery charger is simple to operate. It operates with great reliability. It is completely automatic. When the batteries are completely charged the charger stops itself. As batteries naturally loose power, the battery charger starts again at low intensity as needed to keep them at maximum capacity.

3.2 FUNCTIONS AND INDICATORS

3.2.1 " ON/OFF " SWITCH (AVAILABLE ON 4 AMPS CHARGER MODEL ONLY)

- The " ON/OFF " Switch allows power to be supplied to battery charger.

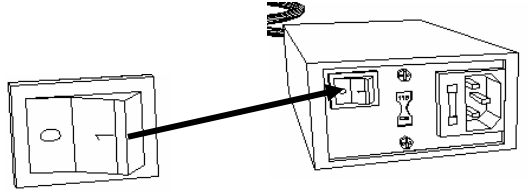

3.2.2 "ON/OFF" INDICATOR (AVAILABLE ON 4 AMPS MODEL ONLY)

- The "ON/OFF " light indicator confirms tension status. It lights red when battery charger is under electrical tension.

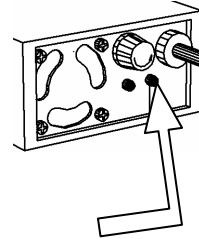

3.2.3 BATTERY STATUS INDICATOR

- Battery status indicator confirms the charger is in charging mode.
- When indicator is yellow the battery charger is performing intense charging.
- When indicator is green, the battery charger is performing light charging.
- Battery charger automatically charges an intense or light mode depending on the charge level already in batteries.

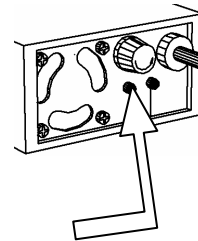

3.2.4 VOLTAGE SELECTOR

- Allows you to choose voltage according to local parameters: 115 or 230 volts.
- It is very IMPORTANT to select appropriate voltage prior to first use. Failure to select appropriate voltage can result in major failure.

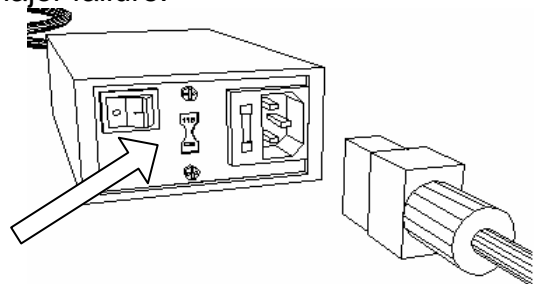

4.1 BATTERY TYPES

We recommend that you entrust installation and maintenance of batteries to a specialized service dealer. Indeed, bad batteries setup can cause significant damage with the apparatus and constitute a danger.

IMPORTANT Recommended Battery type	<i>Lead-acid, 12 VOLTS, DEEP CYCLE (known as Marine, RV or Camping Car type) With Threaded tips</i> <i>Battery size: Group 24: 70 TO 85 AMPS per hour capacity Group 27: 85 TO 105 AMPS per hour capacity</i>
---	---

	<i>DEEP CYCLE batteries are recommended for use with Helitowcart to obtain optimal performance.</i>
---	---

4.2 INITIAL BATTERY CHARGER CONNECTION

- **Make sure voltage selector is set to appropriate country voltage (B).**
- Set the " **ON/OFF** " switch (A) in the **off** position (On 4 amps model only)
- Make sure connector is well inserted (D).
- Connect the 24 VDC (D) plug into socket located on Helitowcart.
- Connect the 115/230 VAC plug (E) to a wall outlet 115/230 volts . A local plug adapter may be required for connection to wall outlet (not included).

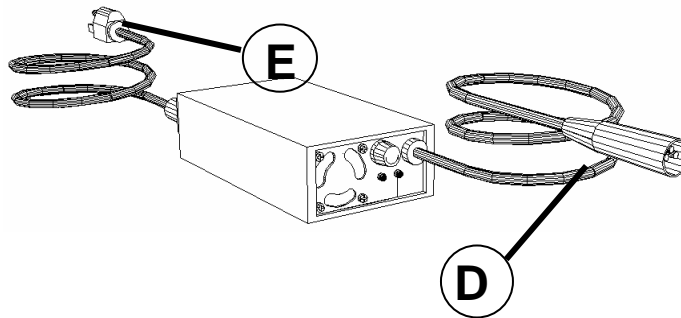
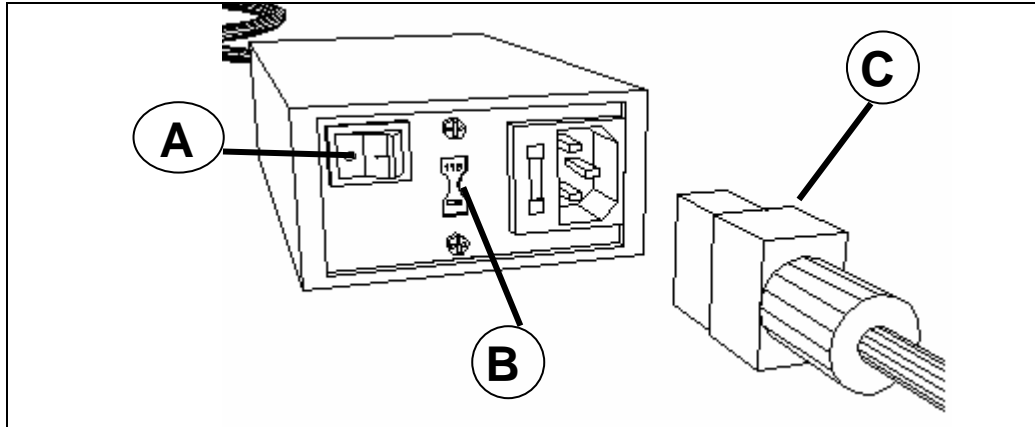

- 1- *Make sure the 24 VDC connector (D) is completely inserted into socket located at front of Helitowcart.*
- 2- *For your safety never cut ground branch from the connector (110 VAC) (E).*
- 3- *Do not to expose charger to bad weather.*

5.1 ACTIVATING CHARGER

- Plug to power source & tow cart
- Set the "ON/OFF " switch (A) in the On position. (On 4 amps model only)
- Two led indicators appear: a red indicator (B) and a yellow indicator (C). This combination indicates that batteries are being reloaded. Note: The red led does not indicate load circuit fault. It indicates that charger is simply under electrical tension.
- When (C) indicator is yellow: charging is performed at high intensity.
- When (C) indicator is green: charging is still being performed but at low intensity.
- When (C) indicator is flashing green: unit is not charging. Consult Breakdown service guide in following section.

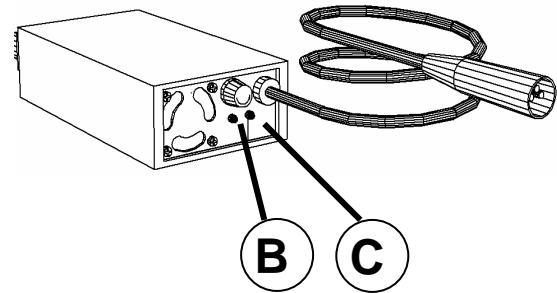
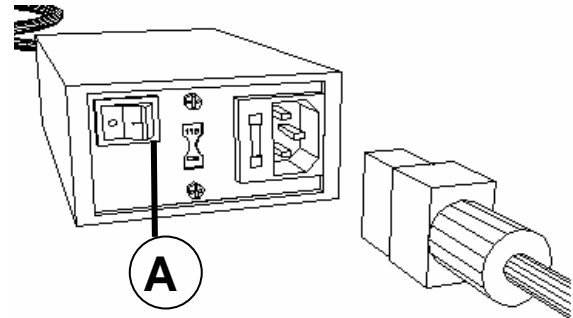

5.2 DEACTIVATING CHARGER

- Set the " ON/OFF " switch (A) in the off position(On 4 amps model only)
- Disconnect charger cable from the Helitowcart
- Disconnect charger from power source.

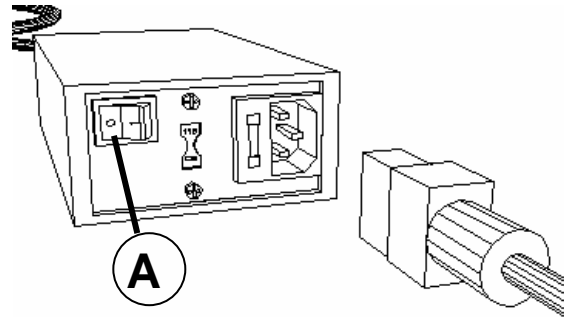

1- **IMPORTANT:** Make sure that 24 VDC connector is completely inserted into socket located on Helitowcart **BEFORE** setting battery charger to the ON position.

2- **IMPORTANT:** Set "ON/OFF" switch to OFF position **BEFORE** disconnecting cable from the Helitowcart.





6.0 BREAK DOWN SERVICE GUIDE



If a faulty battery charger operation is experienced, consult the list below for possible causes and suggested solutions.

	<p><i>If suggested solution does not eliminate problem, consult a technician from an authorized service dealer.</i></p>
---	---

6.1 CHARGER LIGHTS DO NOT IGNITE

POSSIBLE CAUSES	SOLUTIONS
115 VAC connector is not connected to charger.	Connect 115 VAC connector to charger.
115 VAC connector is not connected to power source.	Connect 115 VAC connector to a wall outlet power source.
<u>Input</u> fuse is burned or absent.	<p>Replace fuse by a fuse of same type. use an AGC type Fuse, 3 amps AGC.</p>  <p>Caution, do not use a fuse which has a delayed-action. You may recognize such a fuse by looking at the shape inside the fuse. If it looks like a spring, it is a delayed-action fuse.</p> 

6.2 GREEN LIGHT FLICKERS

POSSIBLE CAUSES	SOLUTIONS
Helitowcart <u>main breaker</u> pulled out	Insert tow cart breaker
Helitowcart faulty connections: <ul style="list-style-type: none"> • Batteries disconnected • Under front end cover, yellow & green wires on the battery charger socket are disconnected • Other disconnected wires in tow cart. 	Connect appropriate wiring according to Helitowcart user manual.
24 VDC connector is not connected to the Helitowcart.	Connect the 24 vdc connector to the Helitowcart.
<u>Output</u> fuse is burned or absent.	Replace fuse by a fuse of same type. Use an AGC type Fuse, 6 amps AGC.  Caution, do not use a fuse which has a delayed-action. You will recognize such a fuse by looking at the shape inside the fuse. If it looks like a spring, it is a delayed-action fuse. 



7.0 WARRANTY

- Vanair inc. provides a warranty for Helitowcart products against any manufacturing defect for a period of one (1) year from the delivery date. This warranty covers the mechanical parts as well as the throttle box, the controller and the communication cables.
- The battery charger has a warranty of six (6) months.
- During the period of validity of this warranty: Vanair inc will repair or replace any defective part provided that it is returned carefully packed to prevent any further damage and sent (prepaid) to an authorized Helitowcart service dealer according to instructions provided by Vanair inc. Such instructions may be obtained by contacting your dealer or Vanair inc.
- This warranty does not apply to the mechanical elements or component damaged by abuse, negligence, accident, wear and tear or setup instruction unauthorized by Vanair Inc.
- Vanair inc. guarantees the availability of components and parts necessary to the operation of the Helitowcart products for period of (2) years from the delivery date.
- The present warranty is given in place of any other written, tacit or statutory warranty. The responsibility of Vanair inc. is limited to repair or to the replacement of any part or component, according to the above-mentioned terms.
- Exclusions and limitations: This warranty does not apply to the products which were the subject of negligence, accident, negligent use, maintenance, defective storage, or of abnormal use. Moreover, this warranty does not apply to products damaged in consequence of a repair or of a modification of a component without the express assent of Vanair inc. neither with repairs and/or modifications not carried out by an Vanair inc. authorized distributor and nor with the products damaged because of circumstances independent of the will of Vanair inc.
- This warranty is limited to repairs and, with absolute discretion of Vanair inc. to the replacement of defective material as expressed with the present warranty. Except for the warranty expressed in this document, Vanair inc. does not grant, relative with its products, any warranty express or implicit, legal or conventional, including for hidden vice, nor no implicit warranty of marketable quality or suitability aiming at a particular use, except contrary stipulation with the present warranty.

- The warranty stipulated above replaces any responsibility or obligation of Vanair inc. concerning the damage coming or referring to the Helitowcart products.
- Vanair inc. cannot, in any case, be held responsible for the particular, indirect or consecutive damage, even if Vanair inc. were informed of the possibility of such damage. The warranty of the distributor is expressly limited to the repair and the replacement of non conforming products as envisaged in this warranty or to the refunding of a sum not exceeding the purchase price of the material in question.
- The stipulations above constitute the declaration of warranty complete and exclusive which applies to the Helitowcart products AND overrides any proposal or former agreement, orally or written, and on any other communication in between Vanair inc. and a particular distributor relative to the Helitowcart warranty.
- Vanair inc. does not assume any risk related to the damage undergone in the course of transport. Vanair inc. does not grant any other warranty but that which is envisaged above. All the warranties, including the implicit warranty of marketable quality and suitability aiming at a particular use are limited to the period indicated above starting from the date of purchase. Vanair inc. cannot be held responsible for the particular, indirect or consecutive damage, from contractual nature that results from an offence or another cause.
- Vanair inc. declines any responsibility for physical injuries or materials damage resulting from an improper use of its products, from a lack of precaution in their use or from a modification made without its written assent.